



**CAR DELIVERY AND RECEIPT PAPER**

Car brand and model: \_\_\_\_\_

Reg. nr: \_\_\_\_\_

Driven kilometres before rental: \_\_\_\_\_

Fuel tank condition: full / half full / empty

**VEHICLE'S TECHNICAL AND EXTERNAL CONDITION<sup>1</sup>:**

Condition: A - excellent; B - good; C - needs repairing / needs replace

	Date before rent:	Date after rent:
General condition		
Tires		
Rims	yes / no, inch	yes / no, inch
Front / back axle		
Engine and starting		
Oil level		
Leaks	yes / no	yes / no
Windscreen / other glasses		
Lights		
Safety tools (fire extinguishers, pharmacy, chocks, warning triangle, vest)	yes / no	yes / no
Mirrors		
The color condition		
Inside condition (armature etc)		
Seats		
Needs deep cleaning	yes / no	yes / no
Electrical accessories		
Brakes		
Handbrake	yes / no	yes / no
Keys	yes / no (how many: pcs)	yes / no (how many: pcs)

**TECHNICAL INSPECTION AND INSURANCE**

Technical inspection valid date		
Kasko insurance valid date		
Regular insurance valid date		
Kasko insurance own responsibility		

**ADDITIONAL FEATURES**

CD-player	yes / no	yes / no
Additional sound system	yes / no	yes / no
Additional alarm	yes / no	yes / no

*I assure that I have reviewed and approved the condition of the vehicle.*

**Before rental:**

**After rental:**

\_\_\_\_\_

\_\_\_\_\_

*Renter*

*Owner*

*Renter*

*Owner*

<sup>1</sup>Car has been reviewed and visually it has not carried out a thorough technical inspection of the act, unless otherwise stated.

Car condition before rent:

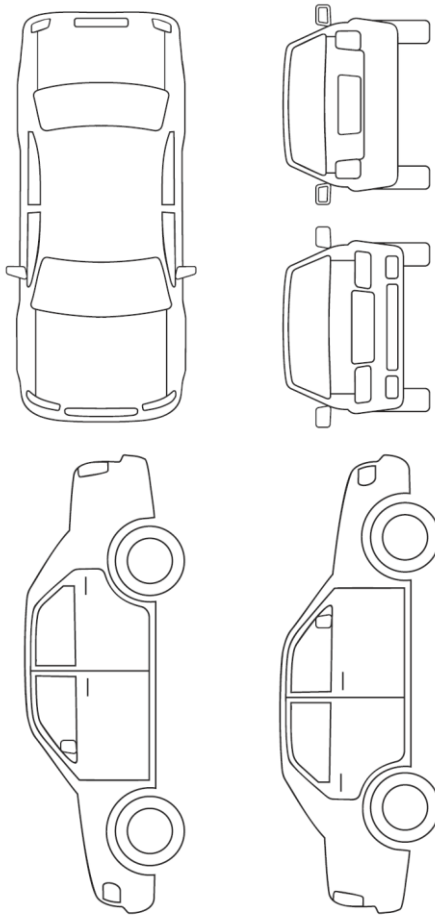

Car condition after rent:

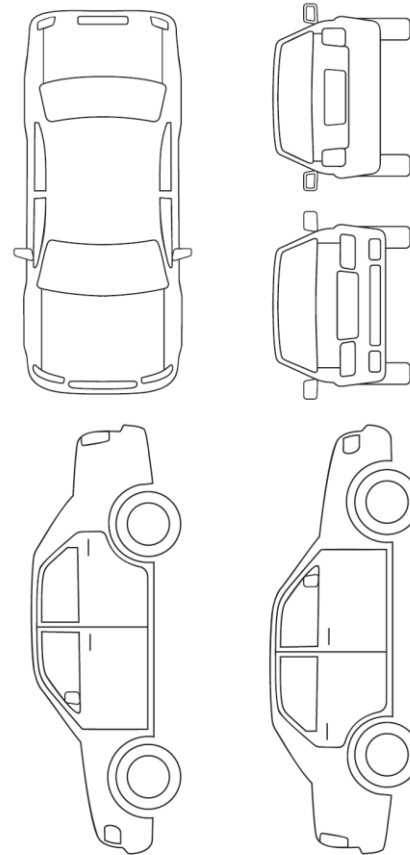

<sup>1</sup>Car has been reviewed and visually it has not carried out a thorough technical inspection of the act, unless otherwise stated.